

**You Will Need To Supply**

- Scissors
- Hammer
- Pencil
- Tape
- Rubbing alcohol
- 5/16" or 8mm Wrench or Adj. Wrench
- Silicone sealant (preferred) or Epoxy
- Two empty soup cans
- Paper
- Superglue (brand of Cyanoacrylate glue)
- Loctite (brand of threadlocker)

### 0. Additional Instructions Online

In addition to these printed instructions there are step by step instructions with photographs online at [www.stirlingengine.com/mm\\_5\\_home.adp](http://www.stirlingengine.com/mm_5_home.adp) or [/mm\\_5\\_home.asp](http://www.stirlingengine.com/mm_5_home.asp).  
These instructions are also available as a PDF file at: [www.stirlingengine.com](http://www.stirlingengine.com)

### 1. Attaching the Thermometer and Engine Decal

Peel the adhesive backing off the Stirling Engine Decal and apply it here.

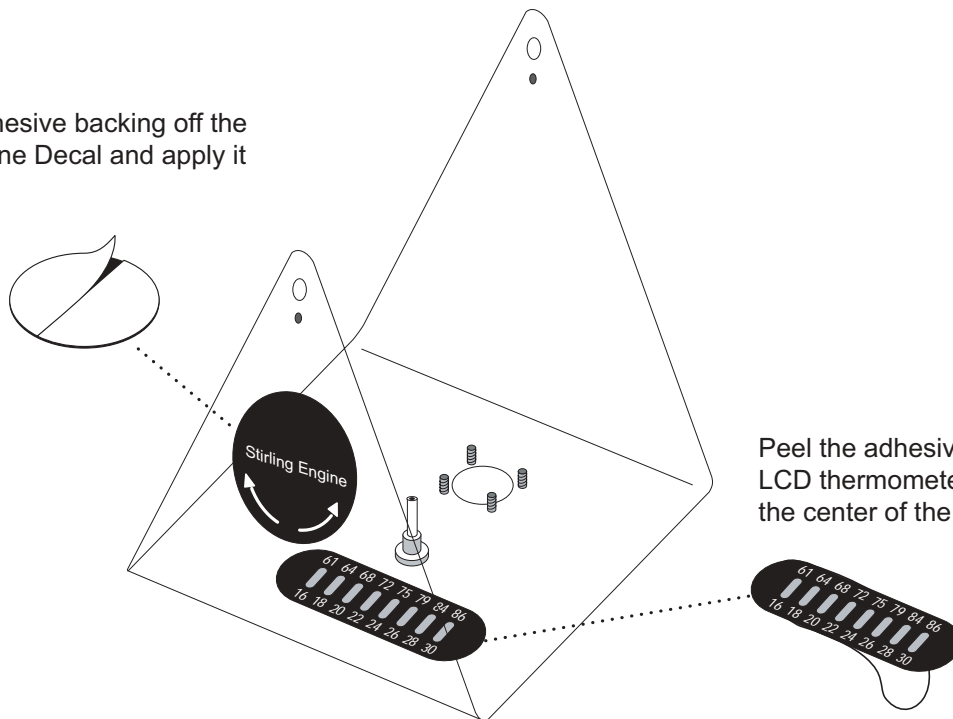

## 2. Gluing Short Brass Tube

Locate the Crankcase and Short Brass Tube. Carefully apply a small bit of adhesive to the outside of one end of the Brass Tube (approximately 1/8" (3mm) from the end), and insert into the Crankcase as shown. Be careful that no adhesive gets into the inside of the Brass Tube. Set the Crankcase Assembly aside to set/dry.

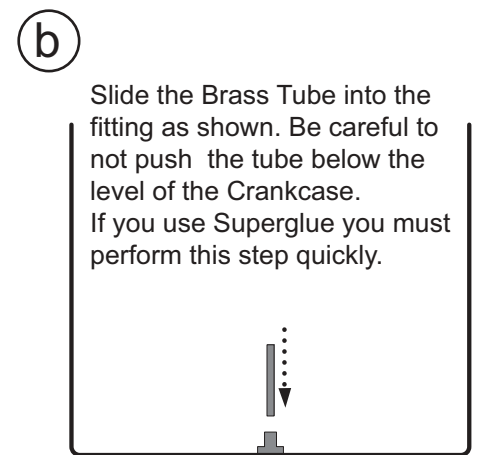
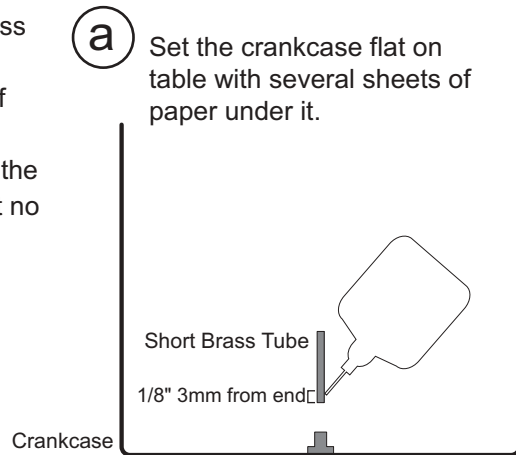

## 3. Displacer Assembly

Locate the Displacer Plug and the Displacer Rod. Press or gently hammer the rod until it goes entirely through the plug, and is flush with the other side. It makes no difference which side of the Plug the Rod is pressed into. If you file the edge off of the Rod before you press it into the Plug, it may enter more easily, and it may scrape less plastic out of the Plug. This is the Displacer Plug Assembly. It is important that the Displacer Rod be at right angles to the Displacer Plug; if this is not the case, gently bend the Rod until it is positioned correctly.

It is important that the Rod be at right angles from the Displacer Plug and that the Plug is vertically centered in the Displacer foam. You can verify correct assembly by holding a rectangular object next to the shaft. © Rotate the Displacer and verify that the Rod is pointing straight up. If it is not, gently adjust the Rod or the Displacer until it is correct. Gently twirl the Displacer to verify that it does not wobble up and down. You can also drop the Displacer into the Crankcase to see whether the Displacer touches the Crankcase with one edge first (bad!) or evenly (good!).

### Verify Geometry

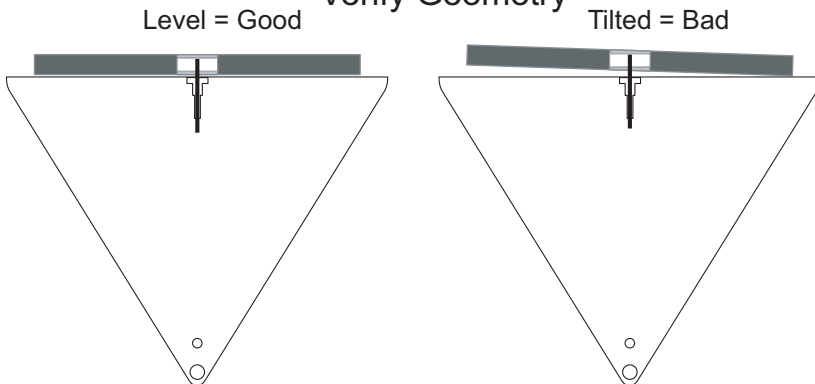

If you are using caulk or epoxy, apply a small amount of adhesive to the edge of the plug and press it into the inside of the Displacer (yellow foam disk). If you are using super glue, assemble the parts dry and then put three drops of Superglue equally spaced around the Plug; then wipe any excess glue off. After verifying the geometry of this assembly set the Displacer assembly aside to set/dry. The next step is to install the Displacer and glue the Cylinder Cap.

Gently tap the Displacer Rod into the Displacer Plug

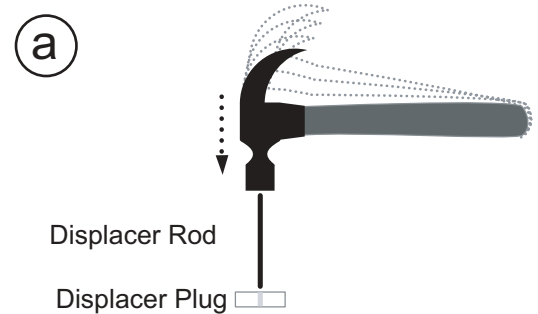

Press the Displacer Rod and Displacer Plug into the hole in the Yellow Displacer Foam

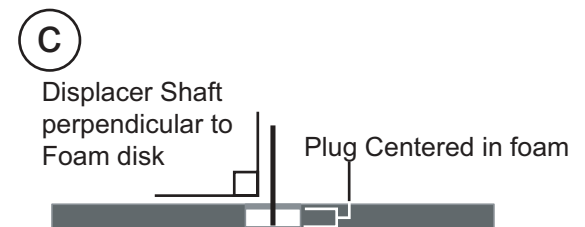
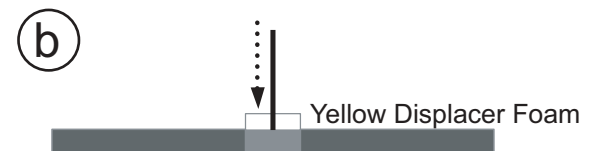

**(d)** Apply 3 dots of Superglue equally spaced around the edge of the plug

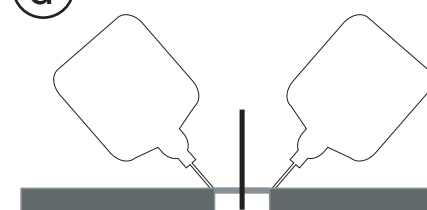

## 4. Gluing Cylinder to Crankcase

Slide the yellow displacer foam assembly in place. Then center the Cylinder Ring around the displacer and trace its outline onto the bottom of the Crankcase. Remove the Displacer Assembly.

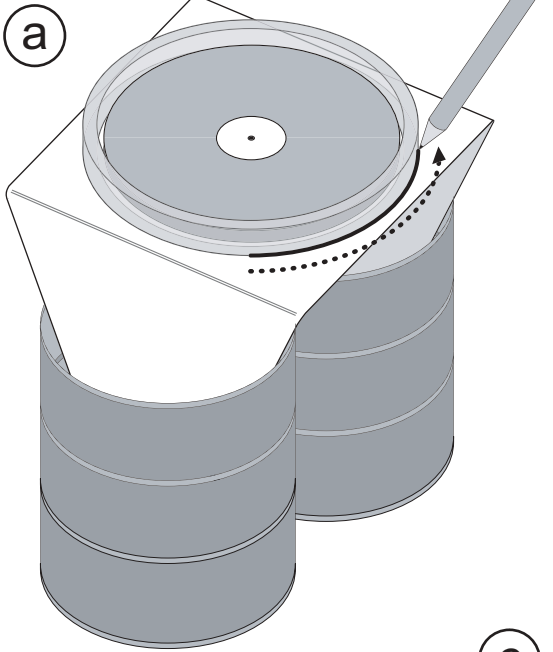

Remove the Cylinder Ring, place it on a piece of heavy paper or cardboard and trace its inner and outer outline onto the paper.

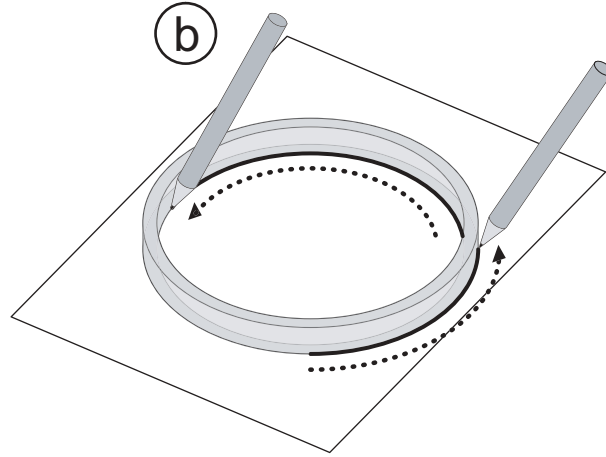

Using the lines traced from the Cylinder, generously apply Silicone Sealant or carefully mixed Epoxy between the traced lines.

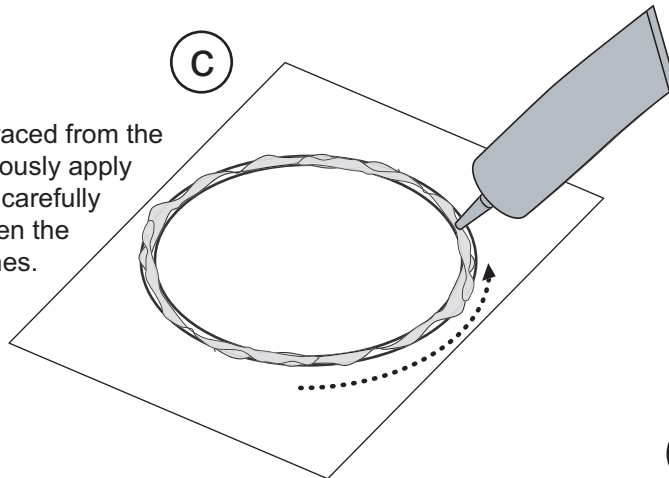

Carefully place the glue covered side of the cylinder inside the outline on the Crankcase. Gently press and twist the cylinder to seat it making sure there are no air gaps. Let it dry.

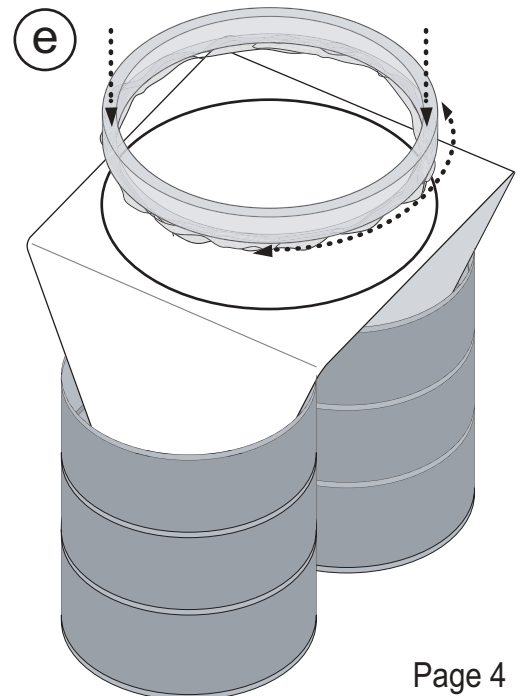

Gently press and twist the cylinder in the ring of glue covering the cylinder end completely with the glue.

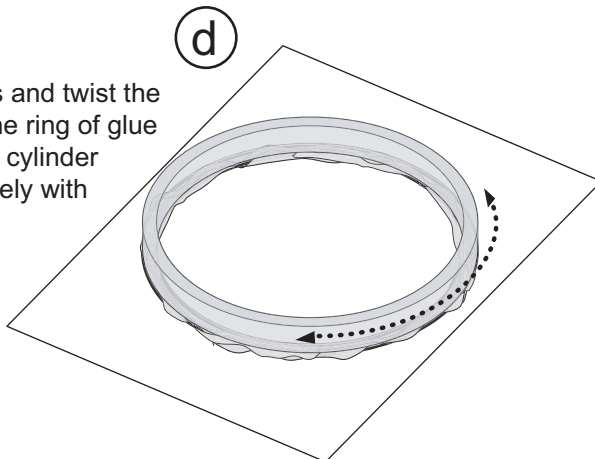

## 5. Gluing Cylinder to Crankcase and Cap

---

After the joint between the Crankcase and the Cylinder Ring has dried, secure the Displacer assembly in the up position with a piece of tape or the rubber tubing (to keep it from being glued to the Cylinder Cap).

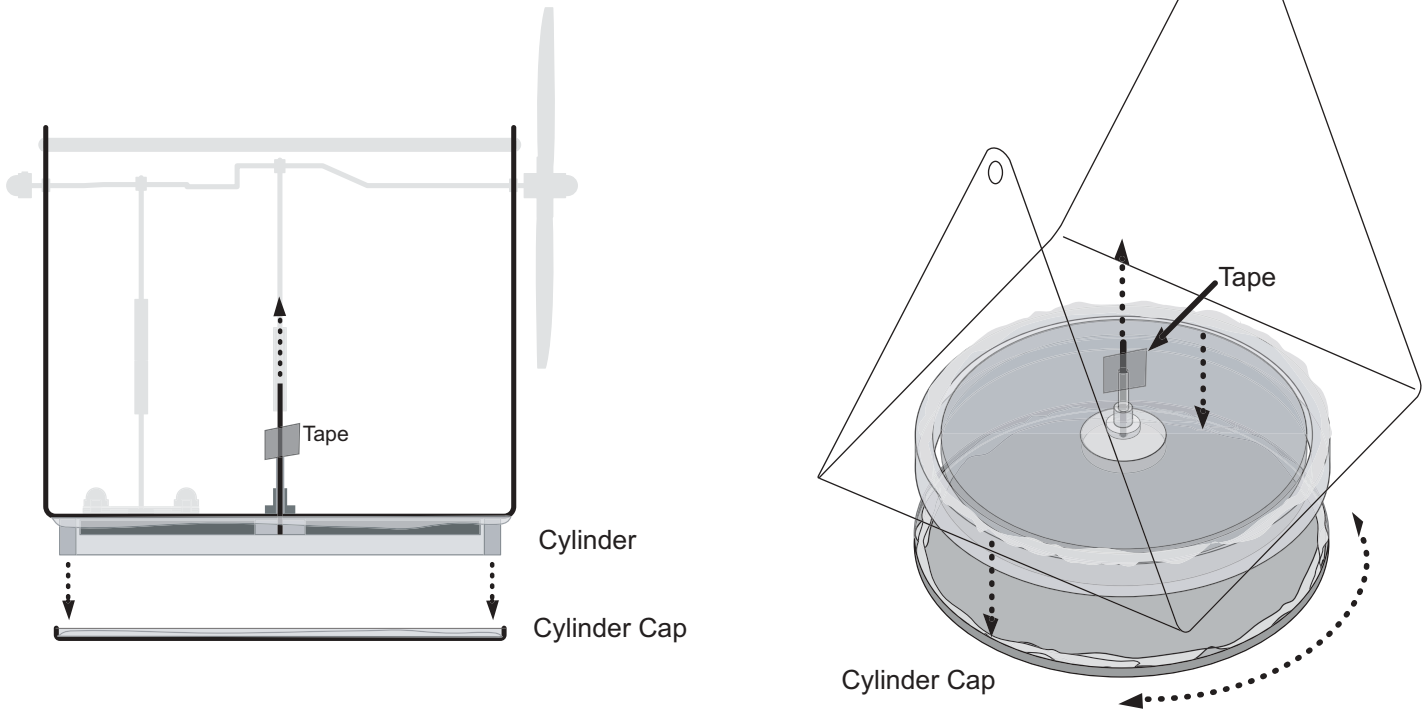

Carefully apply a bead of Silicone Sealant or Epoxy just inside the lip of the Cylinder Cap. Gently press and twist the cylinder into the Cylinder Cap to seat it in the glue and eliminate gaps. Let it dry.

## 6. Piston Assembly and Testing

Place the Black Rubber Gasket on the four studs of the Crankcase Assembly and place the Piston Assembly on top of the Gasket. It will not fit smoothly: there will be bulges and wrinkles. This is normal.

Remove the protective covering from the Large Brass Washer and stack it lightly on top of the Diaphragm Piston Assembly.

Thread four of the Brass Nuts onto the studs a few turns. The nuts should be loose enough that the "rubber" Piston Assembly material slides freely between the Gasket and the Washer, while staying securely on the studs.

Adjusting the Diaphragm Piston Assembly is important. When the Piston Assembly is adjusted properly, the center portion of the piston (the red washer) should travel up and down slightly more than 1/8 inch (3.2 mm). The Piston Assembly must travel through its entire range without stretching the diaphragm. If the diaphragm stretches at all, the engine will run very poorly, or not at all.

*Note that Piston stretching can also occur due to misadjustment of the connectors: see the discussion near the end of these instructions.*

ⓑ Gently pull the Piston Rod up, until the "rubber" Piston material has as few wrinkles as possible (stretching the material slightly). The red washer should be above the flats of the brass nuts. Hold the Piston Assembly in this position and tighten the Brass Nuts finger tight; then tighten the Nuts 1/4 turn further with a wrench. The Piston Assembly must make an air tight seal with the Crankcase. ⓒ

Be very careful not to puncture or tear the "rubber" part of the Piston Assembly. The engine will not run if there are any cuts or tears in the "rubber". Replacement Piston Assemblies are available from your dealer or the American Stirling Company.

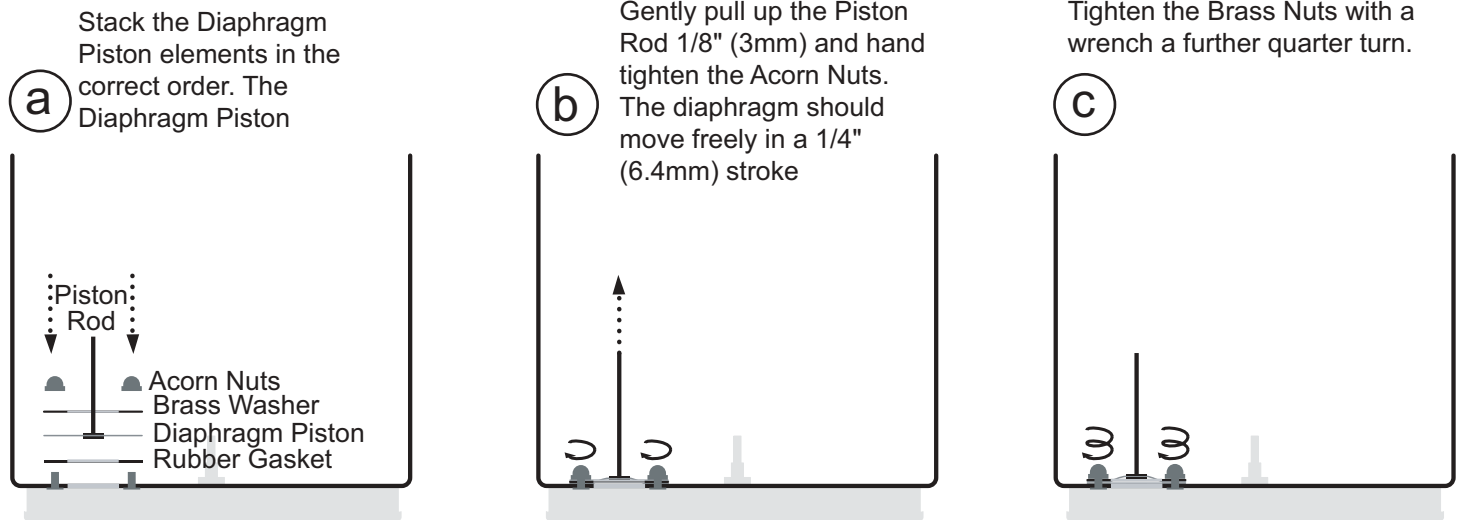

### Air Leak Test

You can now test whether the engine has any air leaks. Gently press the Piston Rod down for about 30 seconds: this forces air out of the Cylinder. Now, quickly (but gently!) pull the Piston Rod up and release it. If the engine is properly sealed, the Piston will snap back to the down position. Air leaks will allow the Piston to remain in the up position. You can view brief video clips of a successful test on the website at: [http://www.stirlingengine.com/images/video\\_pass.MPG](http://www.stirlingengine.com/images/video_pass.MPG)

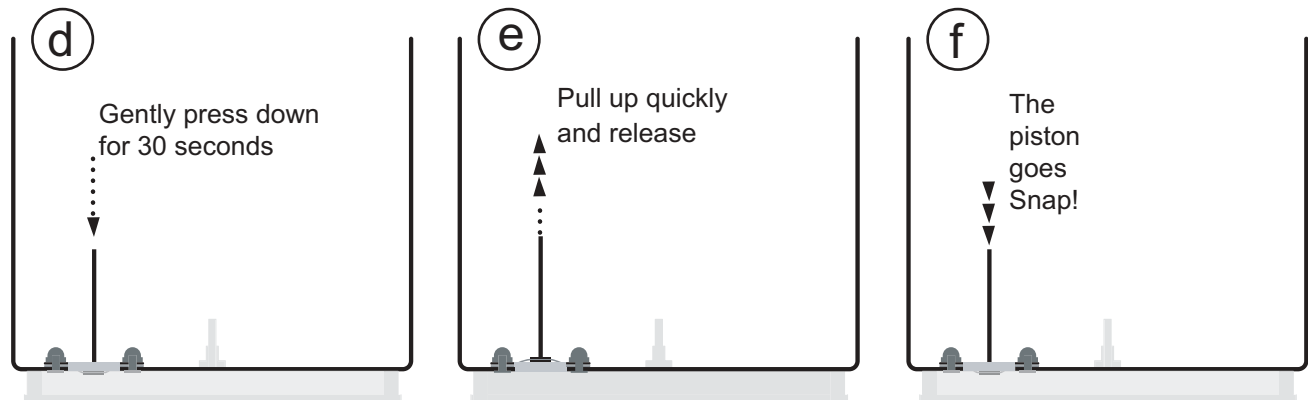

If your engine does not pass this test, you should reseal around the Cylinder and/or check the Gasket/Piston/Washer assembly. You should not proceed further until the engine is properly sealed. Gasket/Piston/Washer problems can usually be solved by reseating the Piston and carefully tightening the Nuts. Cylinder leaks can be fixed by carefully applying more adhesive around the edges where the Cylinder attaches to the Cap and the Crankcase: the only challenge is doing this without leaving a mess behind. Use a toothpick to apply the adhesive and wipe it clean immediately after application. Page 6

## 7. Handle

Place a small drop of adhesive inside each end of the 4.25 inch (10.8 cm) brass tube, the Handle of the engine. Install the Handle in the Crankcase using the two Rivets provided. Rotate the Handle 1/2 turn to ensure a good adhesive bond. Check the assembly carefully as it is drying to make sure that the Rivets do not back out of the brass tubing. Make sure there are no gaps between the Rivets, the Crankcase, and the Handle.

In some cases, the Crankcase may be wider than the Handle. In this case, you must use a rubber band to hold the Crankcase against the Handle while the Adhesive is setting.

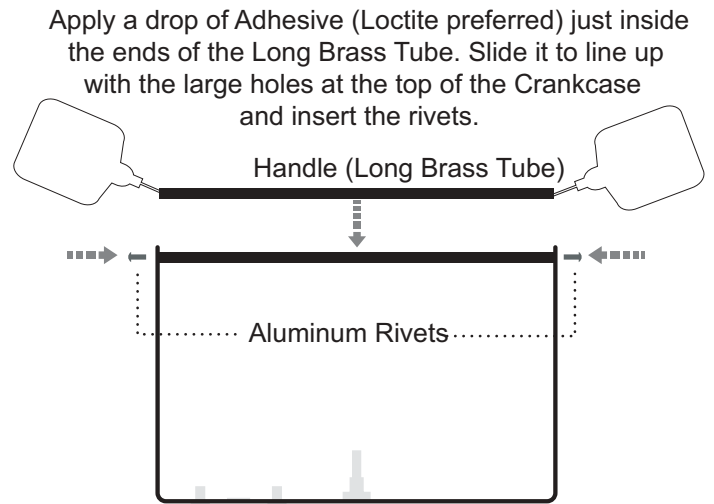

## 8. Crankshaft Assembly

Note that the Upper Piston Rod is longer than the Upper Displacer Rod.

The Crankshaft has a long straight section on one end (on the right in these drawings) and a short straight section on the other end. Slide the Upper Displacer Rod (shorter) on from the long straight end of the Crankshaft (right) until it snaps into place on the first Crankshaft throw. Slide the Piston Rod on the Crankshaft from the short end (left) until it is in place on the other offset.

Cut two one inch (2.54 cm) sections from the Rubber Tubing provided. Slide both rubber tubes on the remaining Small Brass Tube, one from each end until they meet in the middle.

When you are finished with making this assembly, the Brass Tube should be enclosed with two pieces of rubber tubing that meet exactly in the center of the brass. If you have trouble doing this with the tubes dry, try wetting the parts with rubbing alcohol and using a twisting motion. Do not use oil or soap: this will cause the Tubes to wander. This assembly is the Piston Connector. If the tubes do not fit tightly around the upper piston rod please read the note on page 10 of these instructions.

Trim the remaining rubber tubing to 1.25 inches (3.2 cm) and slip this piece onto the Upper Displacer Rod (shorter) until it comes close to the Upper Displacer Bearing, again using rubbing alcohol if necessary. Then slide the Piston Connector onto the Piston Rod (longer). The Crankshaft should look like **(d)**

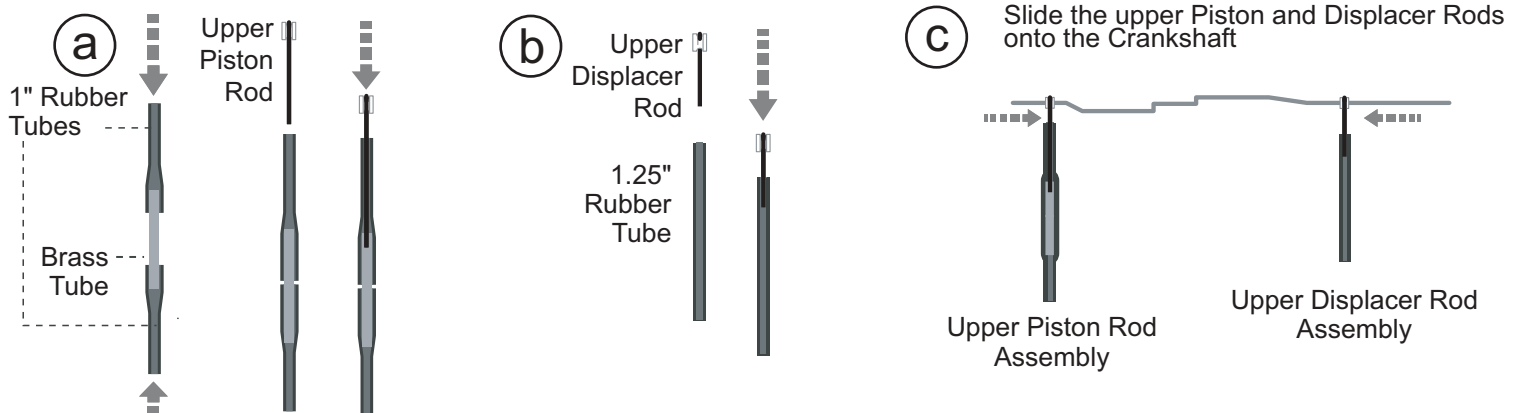

The small gray plastic bearings installed in the Crankcase must be free from flash and other defects. If necessary, ream them out by hand with either a 1/16 inch, #52, or a 1.5 mm drill bit. Install the Crankshaft in the Crankcase so that the Upper Displacer Rod is over the center of the engine and the Piston Rod is above the Piston. Later, when you are ready to run the engine, you will be tempted to oil these bearings. Do NOT do this. The engine runs much better with no oil on the bearings.

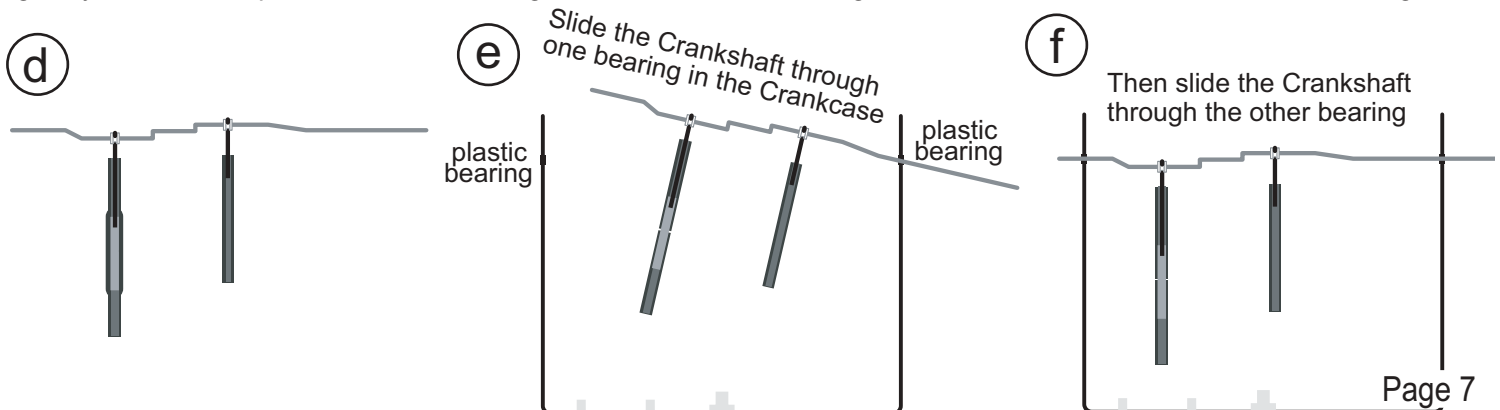

## 9. Propeller and Reducers

---

Fit the Reducers on the Crankshaft. The Short Reducer goes on the piston end of the Crankshaft, and the Long Reducer goes on the other end, with the larger end of the Long Reducer nearer to the Crankcase. If necessary, ream out one end of the Reducers by hand with a 1/16 inch , #52, or 1.5 mm drill bit. Tighten the Reducers on the Crankshaft using the supplied Hex Wrench. The Crankshaft should be able to slide laterally just a bit. If the Reducers are too close to each other, they will bind on the sides of the Crankcase.

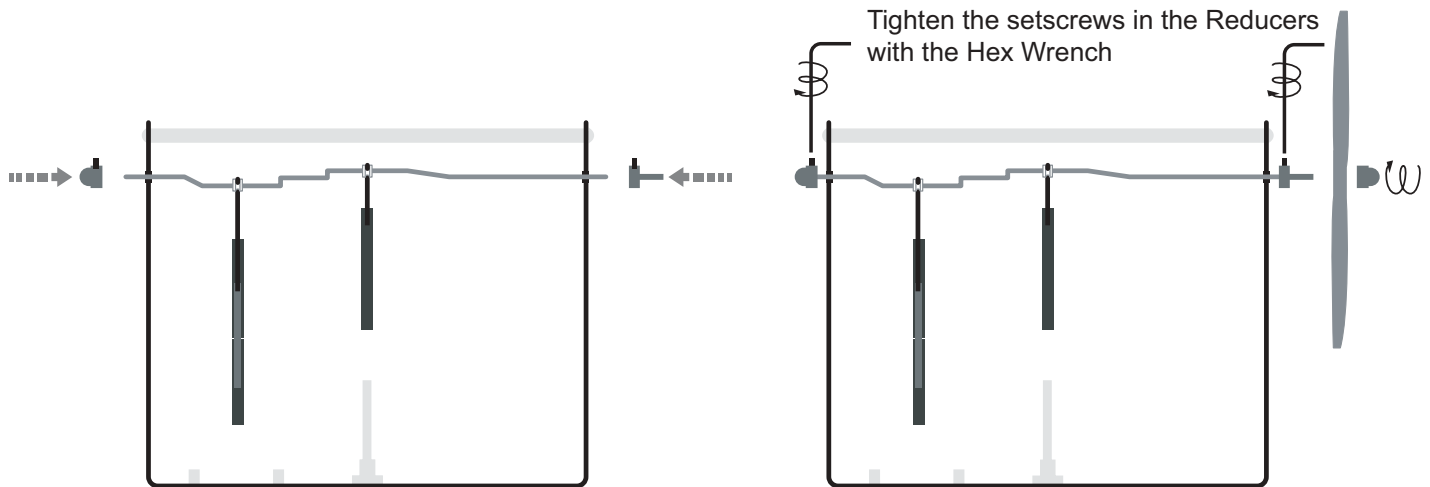

## 10. Attaching the Piston and Displacer to the Crankshaft

---

Press fit the rubber connecting tubes from the Crankshaft onto the metal rods coming up from the Piston and Displacer. Make sure that the Piston rod fits inside the Brass Tube inside the Piston Connector. The Brass Tube is necessary for the connection to be stiff enough. Use rubbing alcohol if you wish when putting the Rubber Tubes over the metal rods. The connectors must be adjusted vertically with care.

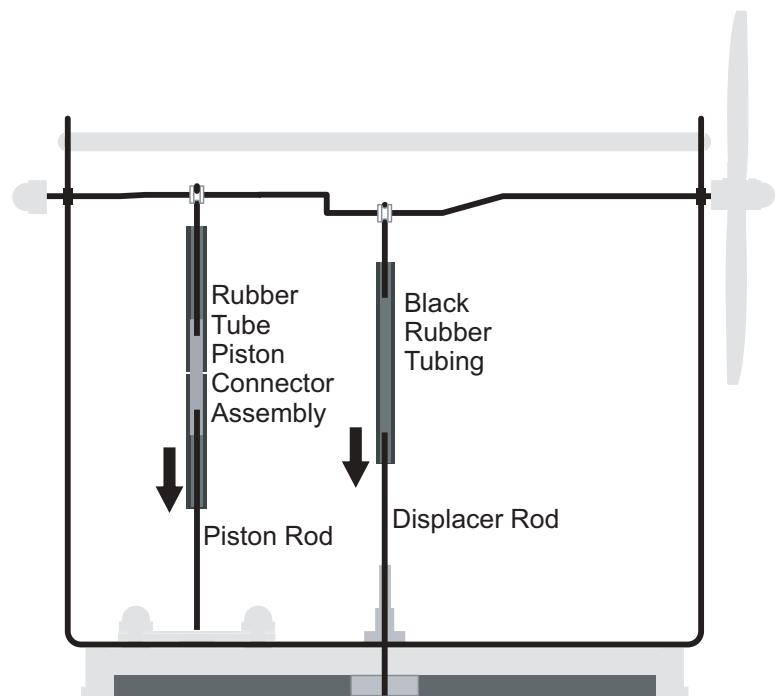



## 11. Adjusting Piston and Displacer Throw

The Displacer should move from the top to the bottom of the Cylinder Ring, and offer no resistance to turning the Crankshaft. The Displacer must not bind at either the top or the bottom of the Cylinder Ring. The "rubber" Diaphragm Piston must neither stretch nor compress as the Crankshaft is turned. If it is well adjusted, it should be slightly wrinkled at the top and bottom of its travel.

Similarly, the Diaphragm Piston Assembly must move evenly above and below the horizontal plane of the Crankcase, and offer no resistance to turning the Crankshaft. The rubber diaphragm itself must never stretch. Adjust the vertical position of the connectors with care, especially the Piston connector.

Be careful not to bend the Crankshaft or tear the Piston diaphragm while adjusting the connectors. One way to protect the Piston diaphragm during adjustment is to hold the Piston Rod at the bottom with a needle nosed pliers, pressing the pliers against the Brass Washer. This ensures that you will not accidentally pull or push the Diaphragm Piston Assembly too much, and break something.

Try to avoid leaving the connectors twisted such that the Diaphragm Piston is twisted or torqued. When in the middle of its range, the diaphragm should be relaxed and wrinkled.

With the Displacer Crank and the Displacer in the down position adjust the rods in the rubber tube so the engine spins freely without the Displacer binding at the top or bottom of the Cylinder Ring.

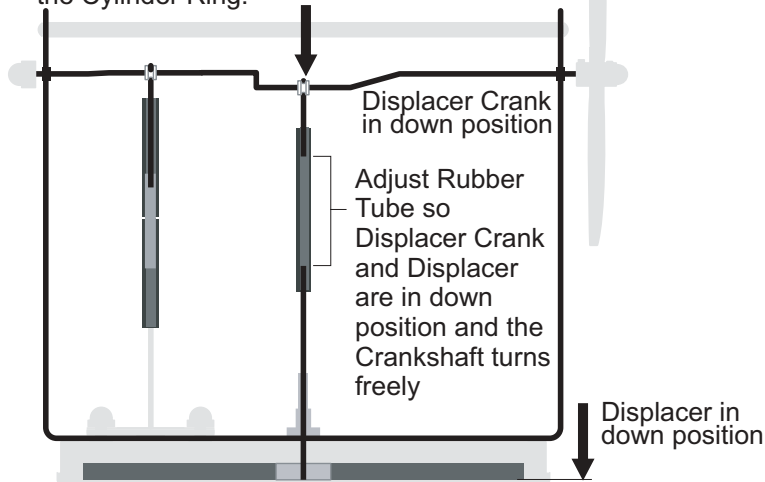

With the Piston Crank and the Diaphragm in the up position adjust the rods in the Piston Connector (see step 8) so the engine spins freely without stretching the diaphragm up or down.

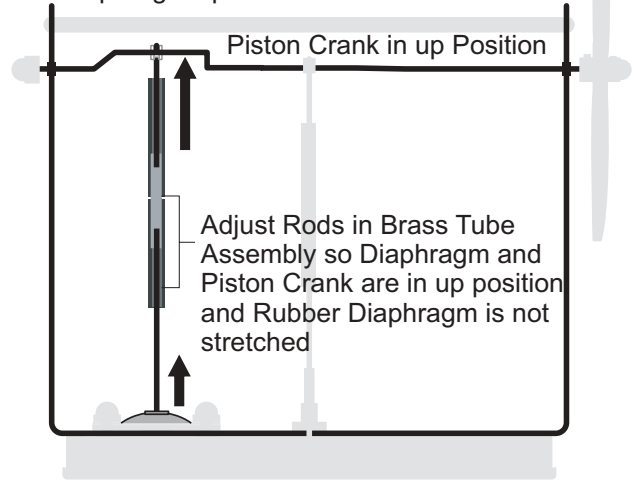

Observe the motion of the rods on the Crankshaft as you slowly rotate the Propeller. Is it binding? If so, figure out where the binding is and adjust the connectors accordingly. Binding is usually caused by the Displacer hitting the Crankcase or the Cylinder Cap, or by the Piston being stretched. When you have everything working smoothly, spin the Propeller quickly by hand. The Propeller should spin about four or five revolutions before stopping

## Running Your Stirling Engine

Put about an inch (2.5 cm) of hot tap water in a coffee mug. Cover the mug with a paper plate and microwave the water until it is boiling vigorously. Be careful, boiling water is dangerous. Don't cover the mug, with plastic wrap, aluminum foil or any tight fitting lid. When the water is finally boiling, remove the paper plate from the mug and place the engine on top. Wait thirty seconds, then flip the prop vigorously through in either direction. If you have applied the Stirling Engine label correctly the correct direction for rotation of the prop is marked. If you are unsure if you have the label on correctly or not then try both directions. If everything is assembled correctly the engine should start right up and run for several minutes.

This engine is optimized for running on small temperature differences. It doesn't care if the bottom of the engine is heated or cooled. If you place it on a pile of ice chips and the room you are in is 72 degrees (22 C) or warmer it will run the opposite direction it ran on hot water.

How to run the engine on ice. In a room that is 72 degrees (22 C) or warmer, rub an ice cube vigorously around the bottom of the engine. Then place the engine on a pile of ice chips (set the chips on a dinner plate) and flip the prop in the opposite direction it turned when running on hot water. Typically it will take about a minute to start. The hotter the room and the colder the ice, the faster it will run.

If you have access to Liquid Nitrogen or any other liquid gasses do NOT try to run this engine on these "cold" sources. It very likely will break. It's possible to get some water in the Cylinder Cap (blue aluminum) have it freeze and pop this Cap off of the engine. If you have assembled your engine using silicone sealant, this is less likely to happen. If this happens to you simply dry the engine off, clean the parts and re-glue it using silicone sealant.

Congratulations on your success! You've have built a fun and educational engine.

You can e-mail comments or questions to: [info@stirlingengine.com](mailto:info@stirlingengine.com)

Copyright © 2001 American Stirling Company. All Rights Reserved.

Illustrations By Michael Crumpton - [michael@artformfunction.com](mailto:michael@artformfunction.com)

## 12. Additional Instructions for your Stirling engine kit.

---

In December 2001 the vendor who supplies the black latex tubing used in this kit supplied us with a batch that had a significantly larger inside diameter than the previous tubing. This had some advantages and some disadvantages.

The advantage was that it made it very easy to slide the tubing over the stainless steel wires. The disadvantage was that the tubing would then slide right off the stainless steel wires too. Fortunately we came up with an elegant solution which we think you will like.

After you have installed the rubber tubing on the engine, roll up the end of the black latex tubing back on itself as shown. Roll the end just like you would roll a sock down. (a)

This tiny “sock” on the end of the rubber tubing looks neat and provides just the right amount of pressure to make adjusting the tubing easy while still holding the rubber firmly on the stainless steel wire. When you use this approach you will probably not need rubbing alcohol to lubricate the black latex tubing. (b)

You might consider using an adhesive such as Loctite to hold the rubber to the steel wire. That will work, but here’s why we chose not to recommend that approach. If you glue the rubber to the steel wire you make adjusting the mechanism later very difficult. Rolling the tiny rubber “sock” on the end of the tubing looks good and makes adjusting the engine later easy.

